



ENGINEERED AIR PRODUCTS

HIGH CAPACITY SLOT DIFFUSER

HI-FLOW



H

SERIES

HI-FLOW

HIGH CAPACITY SLOT DIFFUSERS



Application

Colman's Hi-Flow diffuser represents the very latest in cutting edge design providing dynamic air distribution as well as the aesthetic minimalist appearance demanded by architects in today's modern buildings.

Description

The Hi-Flow diffuser has excellent airflow characteristics when installed as short finite lengths or as long continuous runs. Diffuser butt joints are linked with alignment strips to provide an almost seamless appearance which can incorporate active and non-active sections as well as

architectural mitred corners. End caps are supplied as standard for finite lengths of diffuser.

Available in a range of slot widths and manufactured from extruded aluminium, both sidewall and ceiling mounted diffusers are available with a standard surface mounted flange, flangeless as well as a plastered-in option to give the ultimate discrete appearance.

Hi-Flow is available in lengths of up to 3.0m and the design incorporates keyways for alignment and suspension purposes.

Why Hi-Flow?

Colman's unique design incorporates not only a conventional 1-way discharge pattern associated with high capacity slot diffusers but uniquely incorporates a blade configuration that enables higher induction discharge patterns and improved comfort for the user.

Commissioning and site set-up is exceptionally easy thanks to Colman's unique GlideBar, designed to enable simple one-finger adjustment to gently slide the airflow deflection bar into the desired setting (prior to locking in position) to ensure the optimal coanda and throw pattern is achieved.

Air flow patterns

Hi-Flow S: Sidewall

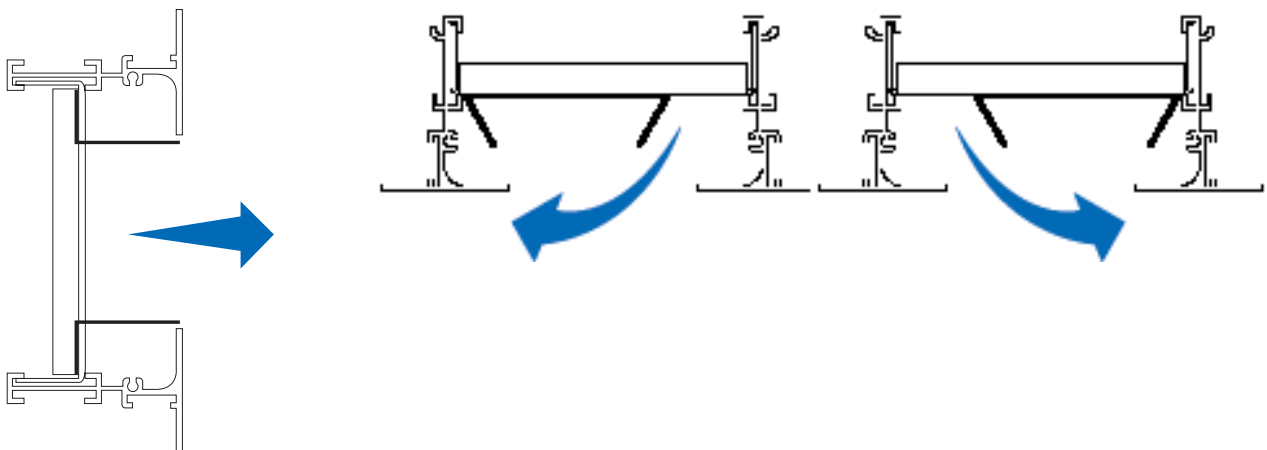

FIXING AND PLENUM DETAILS

HI-FLOW Plaster-in Sidewall Diffuser

Option 1

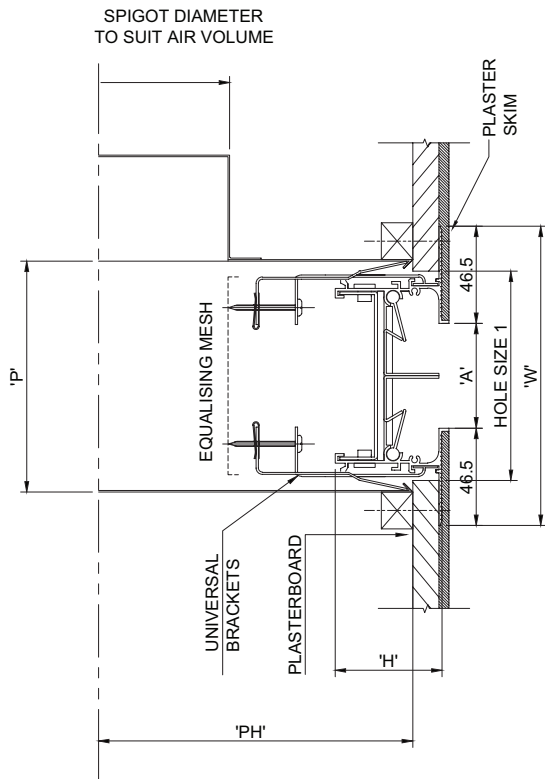

Option 2

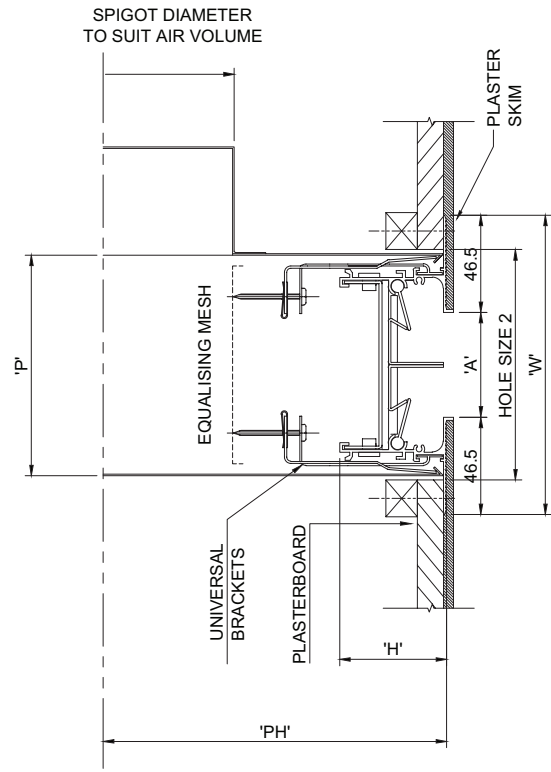

Hi-Flow Diffuser	(A) Airway (mm)	Hole Size 1 (mm)	Hole Size 2 (mm)	(W) Width (mm)	(H) Height (mm)	(P) Plenum Width (mm)	(PH) Plenum Height Spigot + (mm)
P-25	25	75	85	118	51	86	125
P-38	38	88	98	131	51	99	125
P-51	50	100	110	143	51	111	125
P-64	64	114	124	157	51	125	125
P-76	76	126	136	169	51	137	125



Colman's HSP Sidewall Hi-Flow installed at The Whiteley, London.

FIXING AND PLENUM DETAILS

HI-FLOW Flanged Ceiling Mounted Diffuser

Option 1

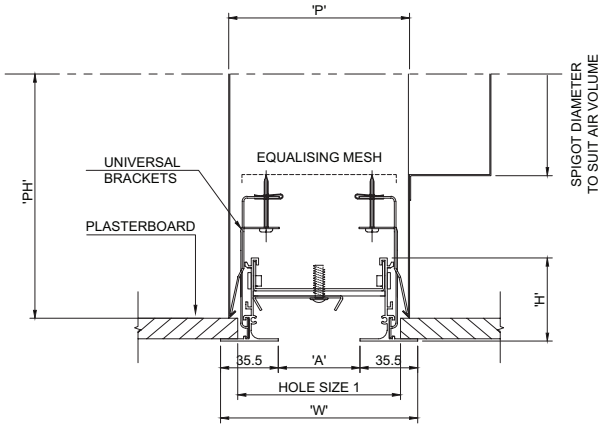

Option 2

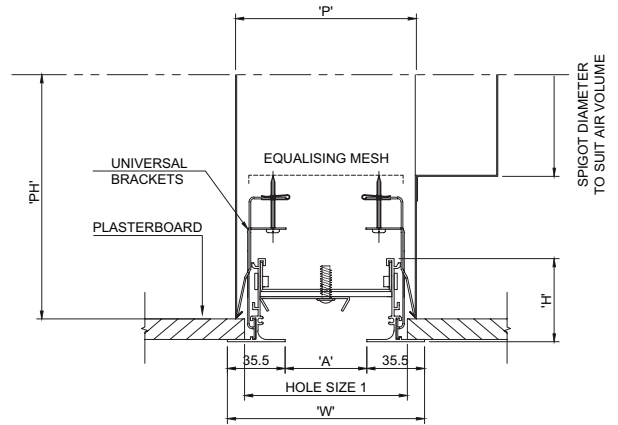

Typical cross section through Hi-FLOW Flanged Diffuser

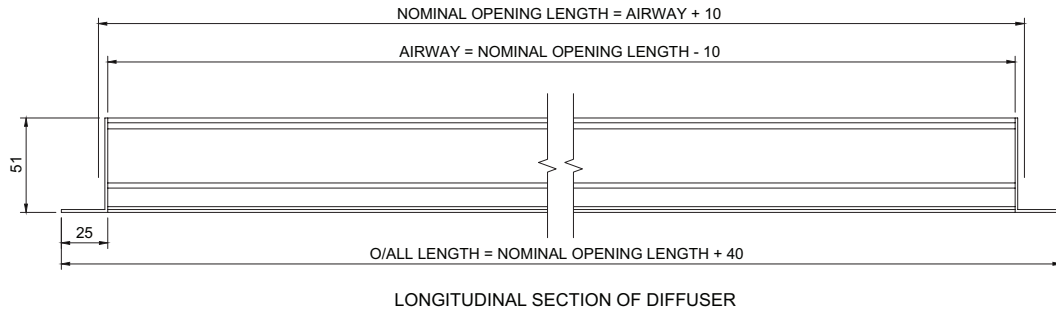

Hi-Flow Diffuser	(A) Airway (mm)	Hole Size 1 (mm)	Hole Size 2 (mm)	(W) Width (mm)	(H) Height (mm)	(P) Plenum Width (mm)	(PH) Plenum Height Spigot + (mm)
C-25	25	75	90	96	51	86	125
C-38	38	88	103	109	51	99	125
C-51	50	100	115	121	51	111	125
C-64	64	114	129	135	51	125	125
C-76	76	126	141	147	51	137	125

FIXING AND PLENUM DETAILS

HI-FLOW Plaster-in Ceiling Diffuser

Option 1

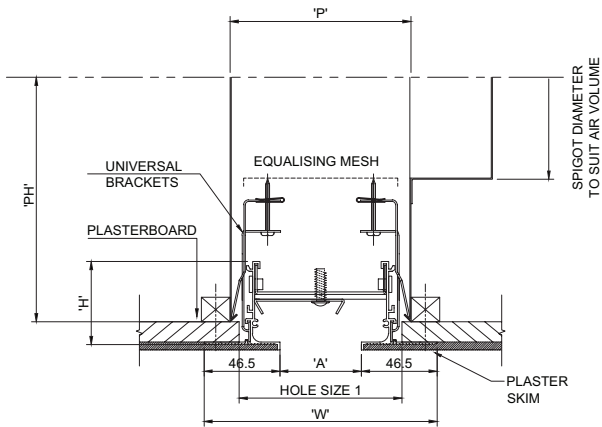

Option 2

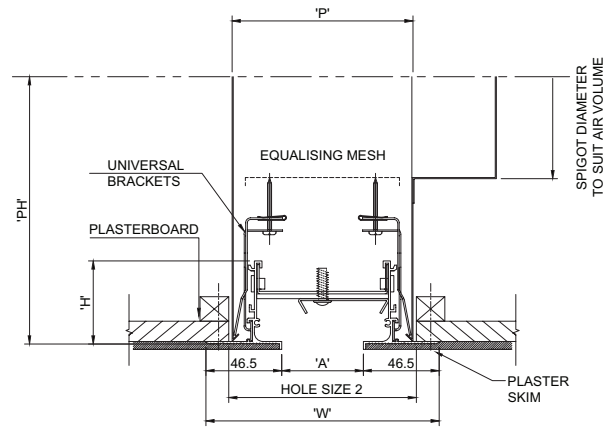

Typical cross section through Hi-FLOW plaster-in Ceiling Diffuser

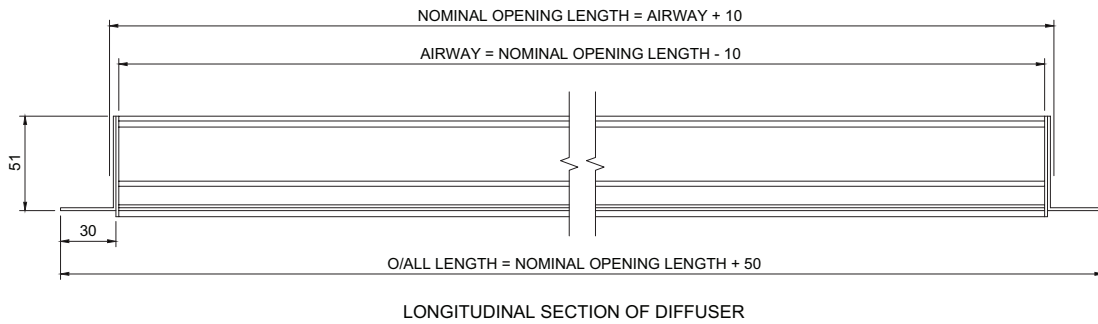

Hi-Flow Diffuser	(A) Airway (mm)	Hole Size 1 (mm)	Hole Size 2 (mm)	(W) Width (mm)	(H) Height (mm)	(P) Plenum Width (mm)	(PH) Plenum Height Spigot + (mm)
C-P-25	25	75	90	118	51	86	125
C-P-38	38	88	103	131	51	99	125
C-P-51	50	100	115	143	51	111	125
C-P-64	64	114	129	157	51	125	125
C-P-76	76	126	141	169	51	137	125

PERFORMANCE DATA

Mounting Throw Pattern	Slot Quantity	Slot Type / Width	Throw to 0.5 m/s Velocity (m)	1.5	2.0	2.5	3.0	3.5	4.0	4.5	5.0	5.5	6.0
Sidewall Mounted Horizontal Throw	1 Slot	Hi-Flow-S-25	Air Vol l/s/m	42	45	52	60	72	84	96	104	114	125
			NR	<15	<15	<15	15	18	20	27	29	31	33
			Pa	6	7	9	12	17	23	26	28	32	36
	1 Slot	Hi-Flow-S-38	Air Vol l/s/m	59	63	72	81	92	104	115	123	141	155
			NR	<15	<15	<15	15	17	20	23	25	28	
			Pa	6	8	11	12	13	14	15	17	22	26
	1 Slot	Hi-Flow-S-51	Air Vol l/s/m	69	83	96	103	114	121	137	144	164	186
			NR	<15	<15	<15	15	15	17	18	20	24	30
			Pa	3	6	7	8	9	10	13	15	18	26
	1 Slot	Hi-Flow-S-64	Air Vol l/s/m	86	102	112	123	134	144	155	170	190	209
			NR	<15	<15	<15	15	17	20	22	24	26	28
			Pa	4	5	6	8	9	11	12	14	16	20
	1 Slot	Hi-Flow-S-76	Air Vol l/s/m	98	114	127	139	153	164	174	190	215	233
			NR	<15	<15	15	15	18	20	22	23	25	28
			Pa	4	5	6	8	9	10	11	12	16	19
Ceiling Mounted Horizontal Throw	1 Slot	Hi-Flow-C-25	Air Vol l/s/m	25	30	38	46	53	59	66	75	82	88
			NR	<15	<15	17	20	24	25	30	33	35	40
			Pa	5	6	9	14	18	25	26	34	44	47
	1 Slot	Hi-Flow-C-38	Air Vol l/s/m	31	39	48	61	66	75	82	90	100	112
			NR	<15	15	21	24	26	30	33	35	38	43
			Pa	5	8	11	16	21	26	32	37	44	54
	1 Slot	Hi-Flow-C-51	Air Vol l/s/m	-	47	53	62	74	85	96	107	117	127
			NR	-	<15	<15	15	21	23	27	30	33	35
			Pa	-	6	8	10	14	19	22	27	32	37
	1 Slot	Hi-Flow-C-64	Air Vol l/s/m	-	-	60	70	81	92	106	120	130	141
			NR	-	-	<15	15	18	22	24	28	30	33
			Pa	-	-	5	8	10	13	17	21	24	28
	1 Slot	Hi-Flow-C-76	Air Vol l/s/m	-	-	-	78	93	105	117	131	144	157
			NR	-	-	-	<15	15	22	24	26	29	32
			Pa	-	-	-	6	9	11	14	17	24	

Performance figures are for diffusers only and assume supply air temperature -10°C to $+10^{\circ}\text{C}$ relative to room temperature.

Throw value is measured horizontally to terminal velocity of 0.5m/s with external pattern (code 0) and ceiling effect.

Pressure drop given is static pressure for diffuser only, when used with a plenum box the following corrections are applied – Supply unit $P_s \times 2.2$, NR +5.

Multiply throw values by 0.7 for installation without ceiling effect.

All NR ratings are based on room absorption of 8db, dampers fully open.

Throw and Noise Correction

Noise Correction	600mm	1000mm	1200mm	1800mm	2400mm
Supply	-2	-1	0	+2	+3
Return	0	+2	+3	+5	+6

Throw Correction	600mm	1000mm	1200mm	1800mm	2400mm
-	0.9	0.95	0	1.1	1.15

Hi-Flow Border Styles

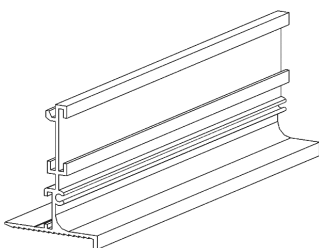

Plaster-in

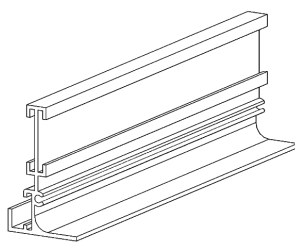

Special Flangeless

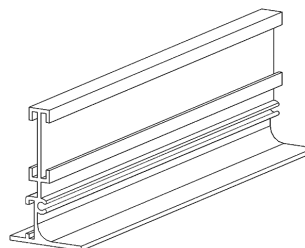

Flangeless

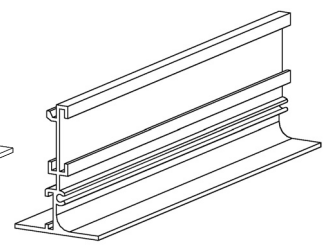

Flanged Surface Mounted

DIFFUSER/PLENUM OPTIONS & ORDER CODES

Options and Order Codes

Diffuser Codes

1. SERIES	2. STYLE	3. SLOT	4. BLADE	5. ACCESSORIES	6. ARRANGEMENT	7. FIXING	8. FINISH
H	S Sidewall C Ceiling P Plaster-in F Flangeless 1 Special	25 25mm 38 38mm 51 51mm 64 64mm 76 76mm	F Full blade	A Standard end caps B Non standard End Caps O None	A Intermediate (no ends) B 2 End Caps C Right hand end cap D Left hand end cap E Mitred end (500mm both Legs) H Non Standard Mitre (Please Specify)	0 None H Hanger brackets U Universal brackets 1 Special	F RAL 9010 matt white O Mill finish P Mill finish, black internal E RAL 9010 gloss white 3 RAL 9006 aluminium 8 RAL 9005 matt black 1 Special

STYLE. If Plaster in or Flangeless is specified please state if diffuser is to be ceiling or sidewall mounted.

Plenum Codes

1. SERIES	2. LINING	3. INSTALLATION METHOD	4. ACCESSORIES	5. ARRANGEMENT	6. SPIGOT TYPE	7. SPIGOT DIAMETER
H	L Lined N Unlined 1 Special	H Clip on Plenum with hanger brackets U Universal brackets	0 None M Cord operated monoblade damper N Cord operated damper damper (matt black) P Internally painted (matt black) 1 Special	S Supply (comes with perforated equalising mesh) E Extract 1 Special	R Round — Side entry S Square — Side entry T Round — Top entry U Square — Top entry 1 Special	A 100 J 450 B 125 L 160 C 150 T 175 D 200 M 180 E 250 R 225 F 300 P 280 G 350 N 315 H 400 1 Special

Example of Order Codes

Diffuser Code: HCFABUF

Standard finish: Powder coated white RAL 9010 matt white.

Example of Order Codes

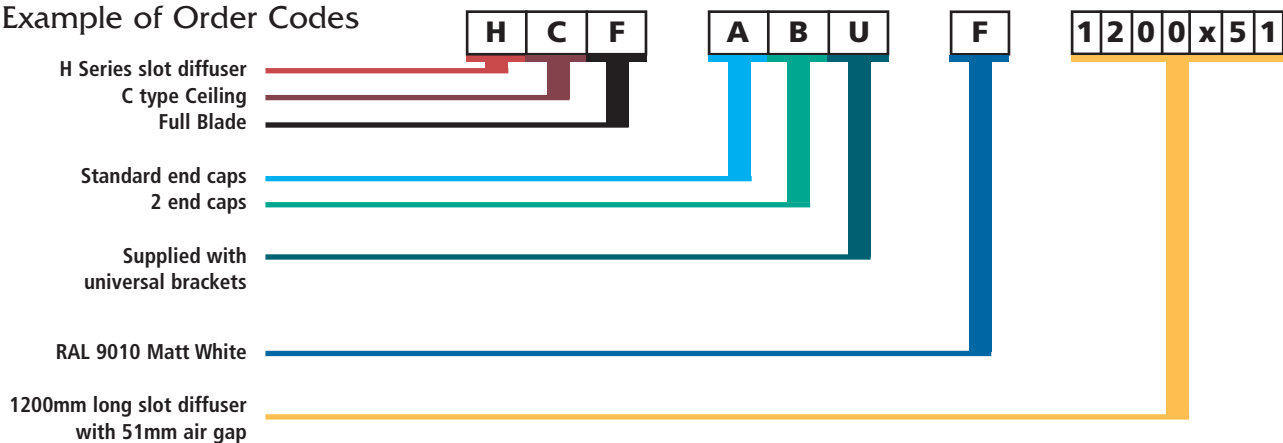

PRODUCT RANGES

GRILLES	DIFFUSERS	LOUVRES
Linear Bar	Linear Slot	External
Ceiling	Louvre Face	Circular
Sidewall	Sidewall	Door
Floor	Perforated Face	Screens
Computer Floor	Circular	Penthouse
Cill	Swirl	Sand Louvres
Single & Double Deflection	Ceiling	Roof Louvres
Egg Crate	Sidewall Fixed & Adjustable	
Hinged Core	Jet Flow / Nozzle	
Door Transfer	Repus Displacement Ventilation	
Security and Prison		
Supply and Extract Valves		

BESPOKE SERVICE

We offer a bespoke design service where standard products do not fit the requirements of the build, we also supply products in special colours and finishes including bronze, brass, gold and chrome to meet Architectural design specifications.



ENGINEERED AIR
PRODUCTS

Colman Air Distribution Limited

Unit 7, High Carr Business Park
Decade Close, Newcastle-Under-Lyme
Stoke-on-Trent, Staffordshire ST5 7UH

Telephone: +44 (0)1782 564383
www.colmanad.com

We reserve the right to alter specifications without notice and products will sometimes be supplied with modifications which do not strictly comply with the descriptions and illustrations in this publication.