

COLMAN
Air Distribution

ENGINEERED AIR PRODUCTS

NOZZLE DUCT DIFFUSER MODELS DKL AND DKS

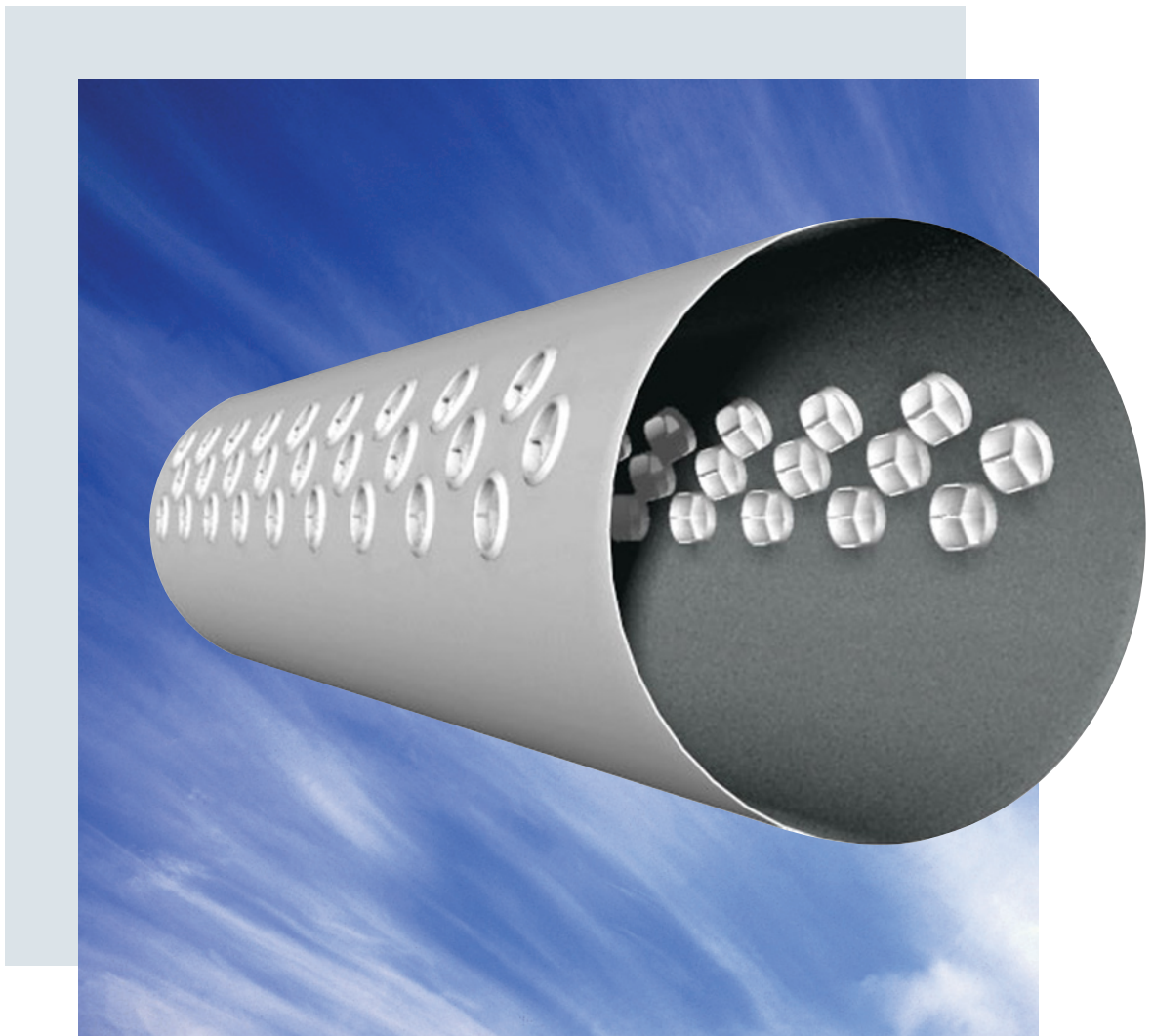

R32/R60

SERIES

R32/R60 SERIES

NOZZLE DIFFUSERS

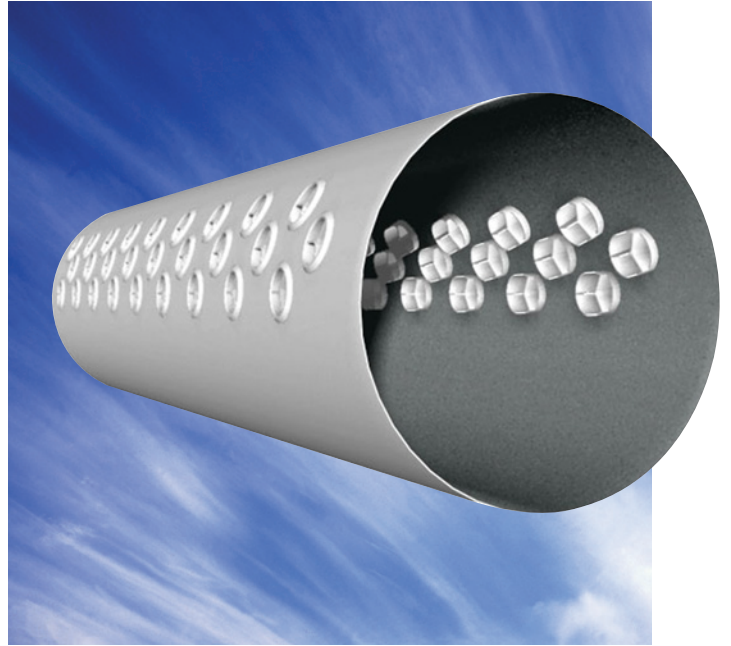

- Constant and even air distribution
- Easy installation
- Low pressure drop
- Flexible in use
- High induction allows for low supply temperatures
- Independent of the coanda effect – accepts variable air volumes

Function

The REPUS®-Nozzles ensure that each nozzle fitted in the same duct will provide the same air flow rate. The even air distribution is created because the flow depends on the total pressure and not the static pressure as on ordinary diffusers. This means that the nozzle can be used in many different applications and is an integral part of the REPUS® Displacement Panels.

Design

Nozzle

Dimensions: 32mm (R32) and 60mm (R60).

Plastic: PP.

Colour: Grey, Black or White.

Nozzle Ducts

A seamless duct formed in galvanised sheet steel.

Size: \varnothing 160 - \varnothing 400.

Available in 1.0m, 1.5m and 2.0m lengths.

Finish

Natural, White NCS 0502-Y (RAL9010), White NCS 0500, Black or Stainless Steel.

Accessories

Painted support brackets.

Fittings.

Air Director for R32 and R60.

Applications

Supply Air Duct

For large premises one or more ducts can be mounted at ceiling level. Normally an adjustment or constant volume damper is fitted on each branch to govern the air flow. The outlet velocity is calculated to provide the correct length of throw and the nozzle can be mounted in multiple rows to provide mixing. The R32-nozzle should be used with low ceiling heights. Recommended outlet velocity 2.5m/s - 5.0m/s.

Condensation or Down Draught Control

Mount the R32-nozzles at 100mm with an air velocity of 5m/s to counteract down draughts and condensation forming in swimming pool, atria or high level glass.

High Velocity

In tall buildings temperature gradients will invariably build up. To provide destratification a duct with R60-nozzles should be mounted at high level in the space.

Sizing

See performance graph.

We also provide assistance in duct sizing and selection using a computer selection program. The program is a big help to optimize the duct for best air distribution.

Selection



Maximum duct velocity 4m/s in comfort areas and up to 5m/s in industrial applications.

Building details:

- Dimensions
- Heat loads
- Air flow rate
- Supply air temperature
- Comfort criteria

We recommend that you use REPUS® MagiCAD software for selection. Please contact us for details.

Product Code

Nozzle type	DKabbb.ccde
L = R32-nozzle, S = R60-nozzle	
Dimension	
160, 200, 250, 315, 400	
Length	
10, 15, 20 (dm)	
Number of rows	
Type of air spread	
1 = one way 	2 = two way 

Avoid Turbulance

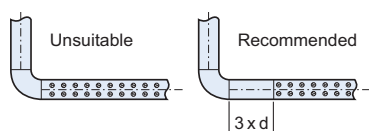

DIMENSIONS AND ORDER CODES R32/R60 — DKL 160

Diagram for Nozzle Ducts with R32

Length	Order Key	Nozzles	Order Key	Nozzles	
2-ways	2000	DKL.160.20.6.2	114		
	3000	DKL.160.30.6.2	168		
	4000	DKL.160.40.4.2	152	DKL.160.40.6.2	228
	5000	DKL.160.50.4.2	190	DKL.160.50.6.2	285
	6000	DKL.160.60.2.2	114	DKL.160.60.4.2	228
	7000	DKL.160.70.2.2	130	DKL.160.70.4.2	260
	8000	DKL.160.80.2.2	152	DKL.160.80.4.2	304
1-way	2000	DKL.160.20.3.1	57		
	3000	DKL.160.30.3.1	84		
	4000	DKL.160.40.3.1	114		
	5000	DKL.160.50.3.1	141		
	6000	DKL.160.60.2.1	114	DKL.160.60.3.1	171
	6000	DKL.160.60.1.1	57	DKL.160.60.2.1	114
	7000	DKL.160.70.1.1	65	DKL.160.70.2.1	130
	8000	DKL.160.80.1.1	76	DKL.160.80.2.1	152

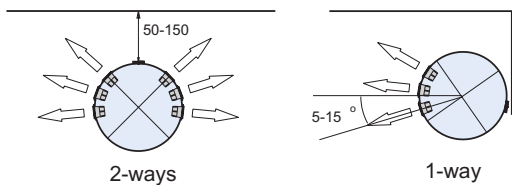
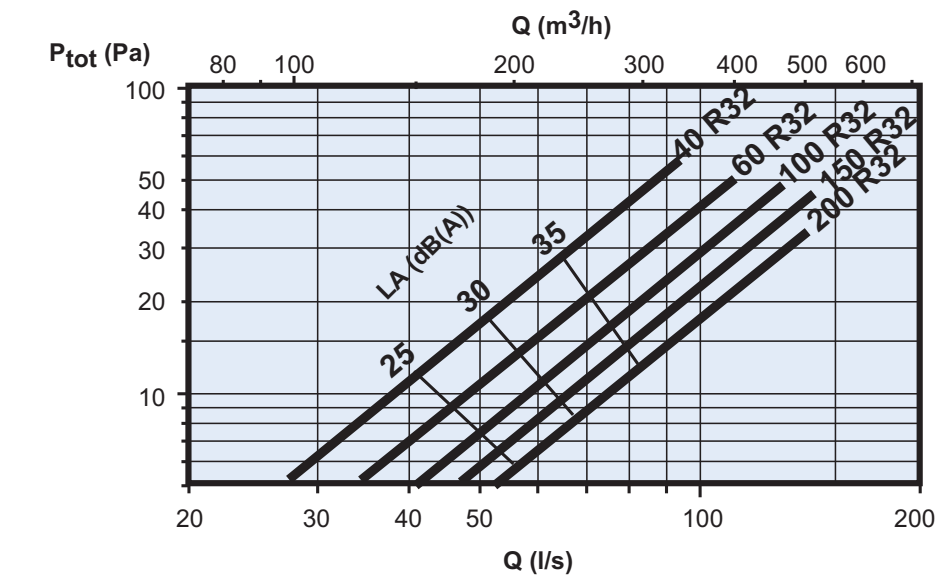

Diagram for nozzle ducts with R32



30-49 R32			
	1,5/2,5	2,8/3,8	3,8/9,8
50-99 R32			
	0,9/0,6	1,7/3,2	2,5/4,3
100-250 R32			
	<1	<1,5	

Air throw
Free jet/wall jet

DIMENSIONS AND ORDER CODES R32/R60 — DKL 200

Diagram for Nozzle Ducts with R32

	Length	Order Key	Nozzles		Order Key	Nozzles
2-ways	2000	DKL.200.20.8.2	152		DKL.200.40.8.2	304
	3000	DKL.200.30.8.2	224		DKL.200.50.6.2	282
	4000	DKL.200.40.6.2	228		DKL.200.60.6.2	342
	5000	DKL.200.50.4.2	188		DKL.200.70.4.2	264
	6000	DKL.200.60.4.2	228		DKL.200.80.4.2	304
	7000	DKL.200.70.2.2	132			
	8000	DKL.200.80.2.2	152			
1-way	2000	DKL.200.20.4.1	76		DKL.200.40.4.1	152
	3000	DKL.200.30.4.1	112		DKL.200.50.4.1	188
	4000	DKL.200.40.4.1	152		DKL.200.60.4.1	304
	4000	DKL.200.40.3.1	114		DKL.200.60.3.1	171
	5000	DKL.200.50.3.1	141		DKL.200.70.3.1	198
	6000	DKL.200.60.3.1	228		DKL.200.80.3.1	228
	6000	DKL.200.60.2.1	114			
	7000	DKL.200.70.2.1	132			
	8000	DKL.200.80.2.1	152			

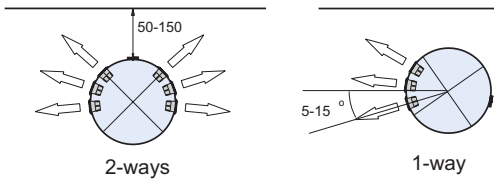
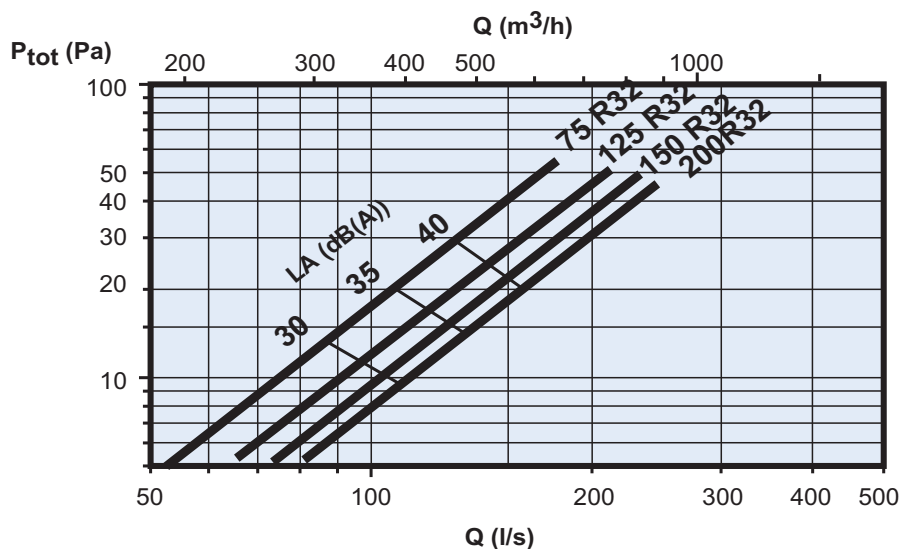

Diagram for nozzle ducts with R32



75-99 R32			
	1,0/2,0	3,8/7,2	
100-149 R32			
	0,4/0,9	1,7/3,3	
150-250 R32			
	<1	1,7/3,2	

Air throw
Free jet/wall jet

DIMENSIONS AND ORDER CODES R32/R60 — DKL 250

Diagram for Nozzle Ducts with R32

	Length	Order Key	Nozzles	Order Key	Nozzles
2-ways	2000	DKL.250.20.10.2	190	DKL.250.20.12.2	228
	3000	DKL.250.30.10.2	280	DKL.250.30.12.2	336
	4000	DKL.250.40.6.2	228	DKL.250.40.8.2	304
	5000	DKL.250.50.6.2	188	DKL.250.50.8.2	285
	6000	DKL.250.60.4.2	228	DKL.250.60.6.2	342
	7000	DKL.250.70.4.2	264	DKL.250.70.6.2	396
	8000	DKL.250.80.2.2	152	DKL.250.80.4.2	304
1-way	2000	DKL.250.20.6.1	114		
	3000	DKL.250.30.6.1	168		
	4000	DKL.250.40.5.1	190	DKL.250.40.6.1	228
	5000	DKL.250.50.4.1	188	DKL.250.50.5.1	235
	6000	DKL.250.60.3.1	171	DKL.250.60.4.1	228
	7000	DKL.250.70.3.1	198	DKL.250.70.4.1	264
	8000	DKL.250.80.3.1	228	DKL.250.80.4.1	304

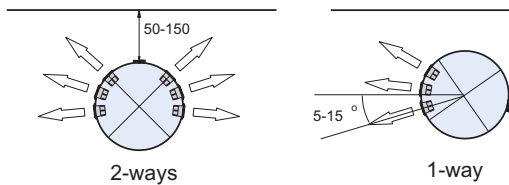
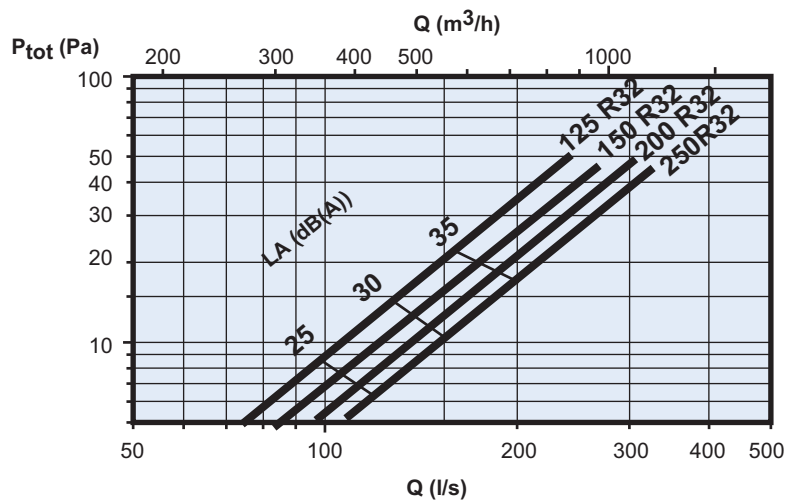

Diagram for nozzle ducts with R32



100-149 R32	1,7/3,2	3,8/7,2
150-199 R32	0,9/1,8	3,8/7,2
200-250 R32	0,6/1,2	1,7/3,2

Air throw
Free jet/wall jet

DIMENSIONS AND ORDER CODES R32/R60 — DKL 315

Diagram for Nozzle Ducts with R32

	Length	Order Key	Nozzles	Order Key	Nozzles
2-ways	2000	DKL.315.20.14.2	266		
	3000	DKL.315.30.10.2	280	DKL.315.30.12.2	336
	4000	DKL.315.40.8.2	304	DKL.315.40.10.2	380
	5000	DKL.315.50.6.2	282	DKL.315.50.8.2	376
	6000	DKL.315.60.6.2	342	DKL.315.60.8.2	456
	7000	DKL.315.70.4.2	264	DKL.315.70.6.2	396
	8000	DKL.315.80.4.2	304	DKL.315.80.6.2	456
1-way	2000	DKL.315.20.7.1	133		
	3000	DKL.315.30.7.1	196		
	4000	DKL.315.40.6.1	228	DKL.315.40.7.1	266
	5000	DKL.315.50.5.1	235	DKL.315.50.6.1	282
	6000	DKL.315.60.4.1	228	DKL.315.60.5.1	285
	7000	DKL.315.70.4.1	264	DKL.315.70.5.1	330
	8000	DKL.315.80.4.1	304	DKL.315.80.5.1	380

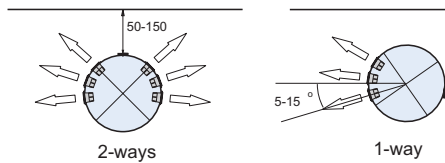
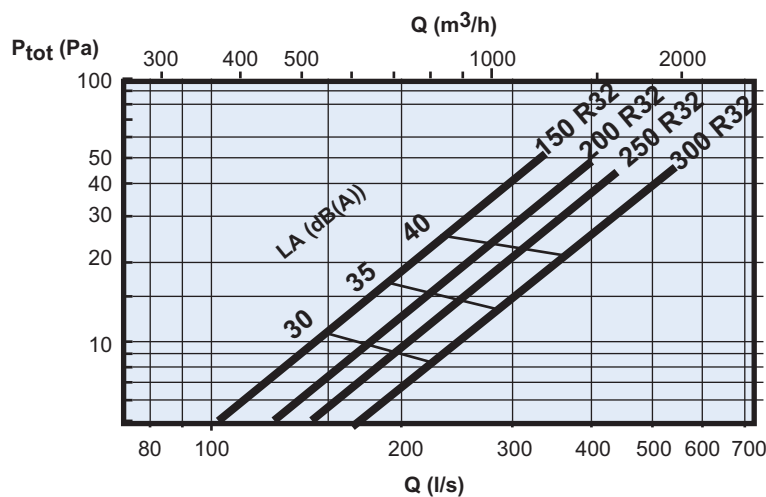

Diagram for nozzle ducts with R32



125-199 R32	1,5/2,5	2,5/5	
200-249 R32	1/2	4/7	
250-350 R32	1/1,5	2/4	

Air throw
Free jet/wall jet

DIMENSIONS AND ORDER CODES R32/R60 — DKL 400

Diagram for Nozzle Ducts with R32

	Length	Order Key	Nozzles	Order Key	Nozzles
2-ways	2000	DKL.400.20.18.2	342		
	3000	DKL.400.30.16.2	352	DKL.400.30.18.2	396
	4000	DKL.400.40.14.2	532	DKL.400.40.16.2	608
	5000	DKL.400.50.12.2	564	DKL.400.50.14.2	658
	6000	DKL.400.60.10.2	570	DKL.400.60.12.2	684
	7000	DKL.400.70.8.2	528	DKL.400.70.10.2	660
	8000	DKL.400.80.6.2	456	DKL.400.80.8.2	608
	9000	DKL.400.90.4.2	340	DKL.400.90.6.2	510
	1-way	2000	DKL.400.20.9.1	171	
3000		DKL.400.30.9.1	252		
4000		DKL.400.40.8.1	304	DKL.400.40.9.1	342
5000		DKL.400.50.7.1	329	DKL.400.50.8.1	376
6000		DKL.400.60.7.1	399	DKL.400.60.8.1	456
7000		DKL.400.70.6.1	396	DKL.400.70.7.1	462
8000		DKL.400.80.6.1	456	DKL.400.80.7.1	532
9000		DKL.400.90.6.1	510	DKL.400.90.7.1	595

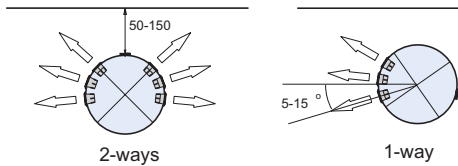
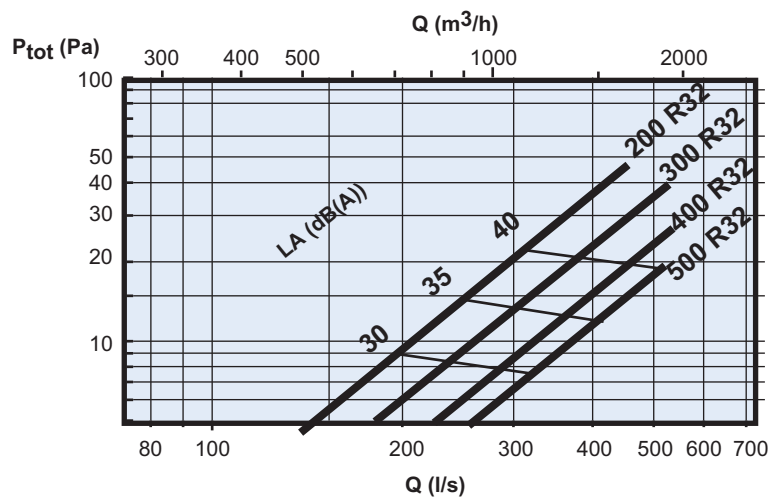

Diagram for nozzle ducts with R32



180-299 R32	1,6/1,7 2,0/3,0
300-399 R32	1/2 3/6
400-500 R32	0,8/1,2 1,8/3

Air throw
Free jet/wall jet

INSTALLATION AND MAINTENANCE R32/R60

Typical Installations

Class rooms, offices, shops (R32-nozzles)

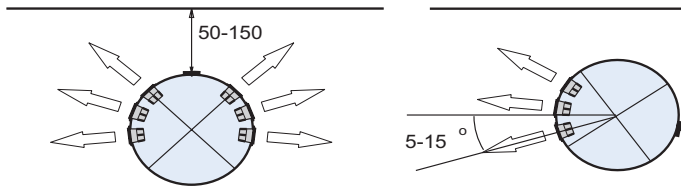

Mounted R60-nozzles with air director in a painted duct.

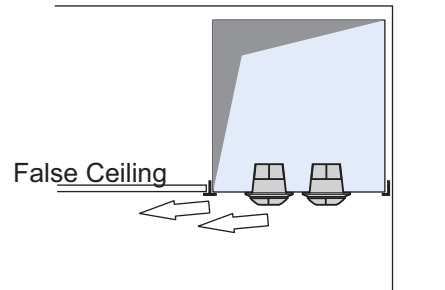

Store rooms, leisure centres

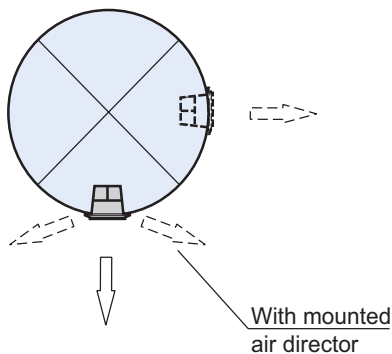

Defrost windows (R32 or R60 Nozzles)

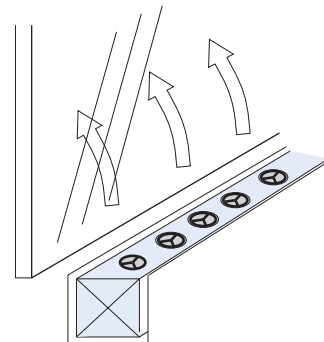

Installation Instructions

Nozzles

If fitting nozzles to your own duct use a 32 or 60 mm hole saw suitable for the purpose. Warming the nozzles will make them easier to install. Maximum temperature 100°C. Take all precautions when using hot water. When fitting nozzles note that the arrow on the nozzle indicates the correct air direction.

Nozzle Duct

The simplest suspension method is to use studding onto a threaded connector set on top of the nozzle duct.

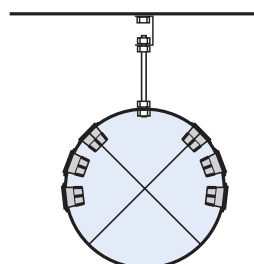

Maintenance

The duct is designed for ease of maintenance. Clean with damp cloth and a mild detergent.

TYPICAL INSTALLATIONS

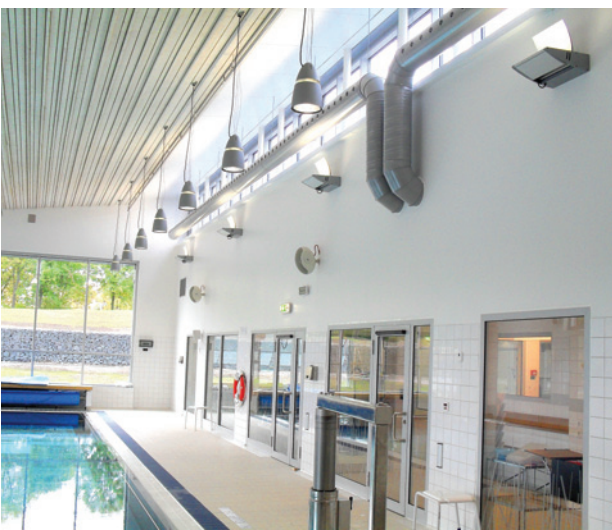

PRODUCT RANGES

GRILLES	DIFFUSERS	LOUVRES
Linear Bar	Linear Slot	External
Ceiling	Louvre Face	Circular
Sidewall	Sidewall	Door
Floor	Perforated Face	Screens
Computer Floor	Circular	Penthouse
Cill	Swirl	Sand Louvres
Single & Double Deflection	Ceiling	Roof Louvres
Egg Crate	Sidewall Fixed & Adjustable	
Hinged Core	Jet Flow / Nozzle	
Door Transfer	Repus Displacement Ventilation	
Security and Prison		
Supply and Extract Valves		

BESPOKE SERVICE

We offer a bespoke design service where standard products do not fit the requirements of the build, we also supply products in special colours and finishes including bronze, brass, gold and chrome to meet Architectural design specifications.



ENGINEERED AIR
PRODUCTS

Colman Air Distribution Limited

Unit 7, High Carr Business Park
Decade Close, Newcastle-Under-Lyme
Stoke-on-Trent, Staffordshire ST5 7UH

Telephone: +44 (0)1782 564383
www.colmanad.com

We reserve the right to alter specifications without notice and products will sometimes be supplied with modifications which do not strictly comply with the descriptions and illustrations in this publication.